



Duro-Sense Corporation



ENGINE COMPRESSOR THERMOCOUPLES

ENGINE-COMPRESSOR THERMOCOUPLES

Duro-Sense Engine-Compressor Thermocouples (ECT) are designed and manufactured to provide the finest quality available to insure maximum reliability. The unique preparation of premium grade conductors, MgO insulation and stainless steel tubing through reduction swaging and drawing produces a uniform thickness of sheath and high density of insulation. The result is a product that is mechanically strong and impervious to penetration of corrosive gases and moisture. This material has the advantage of high dielectric strength plus the ability to withstand severe physical abuse. It can be formed in a radius equal to its own diameter without damage and can be brazed without loss of dielectric integrity. They are available in a variety of configurations to satisfy numerous applications.

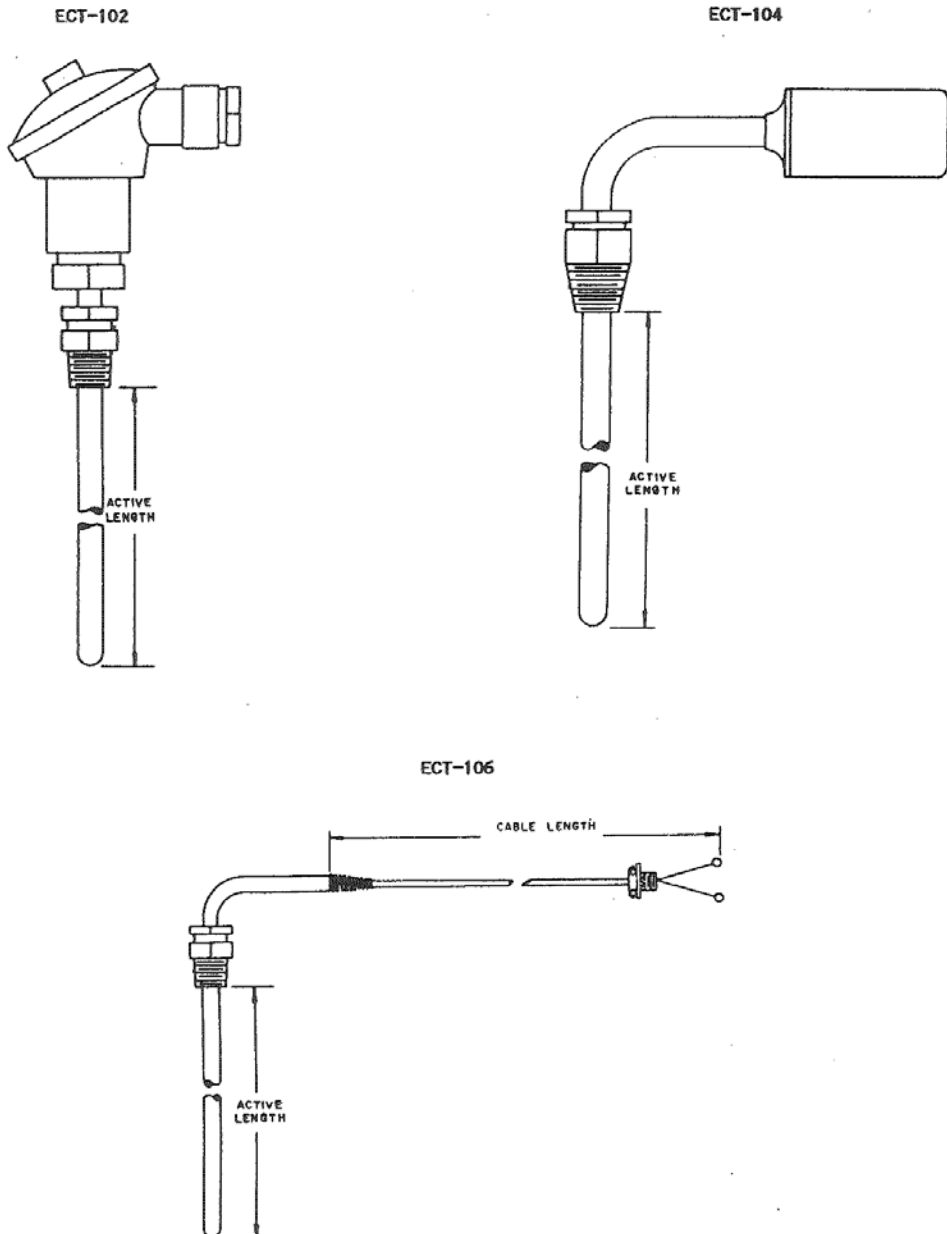

DURO-SENSE CORPORATION 869 Sandhill Ave., Carson, CA 90746

Phone: (310) 533-6877 -- Fax: (310) 533-0330 -- E-mail: sales@duro-sense.com -- Website: www.duro-sense.com

ENGINE-COMPRESSOR THERMOCOUPLES

Thermocouple Ordering Information

“102” Style

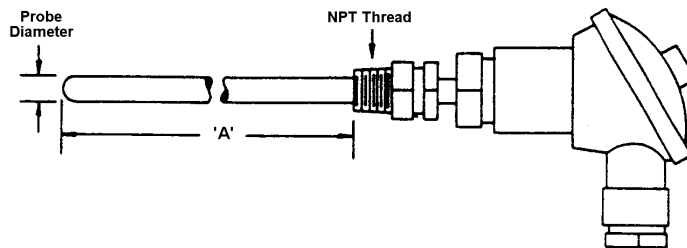

Part #: ECT-102-----

Junction (Table 1) Calibration (Table 2) Diameter (Table 3) 'A' Length (inches) Mounting Ftg. (Table 4)

NOTE: For any additional modifications to this assembly, add “-MOD” to the end of the part number and provide a physical description of the modification.

Table 1
Junction

P/N	Description
U	Ungrounded
G	Grounded
E	Exposed
UU	Uncommon-Ungrounded
GG	Dual Grounded
EE	Dual Exposed
X	Special

Table 2
Calibration

P/N	Description
J	Type 'J'
K	Type 'K'
E	Type 'E'
N	Type 'N'
X	Special

Table 3
Diameter

P/N	Description
1/8	1/8" O.D.
3/16	3/16" O.D.
1/4	1/4" O.D.
3/8	3/8" O.D.
X	Special

Table 4
Mounting Fitting

P/N	Description
A	1/8" NPT Adjustable
B	1/4" NPT Adjustable
C	1/2" NPT Adjustable
D	1/2" NPT Fixed †
E	3/8" NPT Adjustable
F	3/4" NPT Adjustable
X	Special

† - Only Available in 3/8" diameter

Example:

ECT-102-U-J-1/4-4.5-48-C

102 Style, Type 'J', 1/4" diameter sheath, 4.5" active length, 1/2" NPT adjustable mounting fitting



DURO-SENSE CORPORATION 869 Sandhill Ave., Carson, CA 90746

Phone: (310) 533-6877 -- Fax: (310) 533-0330 -- E-mail: sales@duro-sense.com -- Website: www.duro-sense.com

ENGINE-COMPRESSOR THERMOCOUPLES

Thermocouple Ordering Information

“104” Style

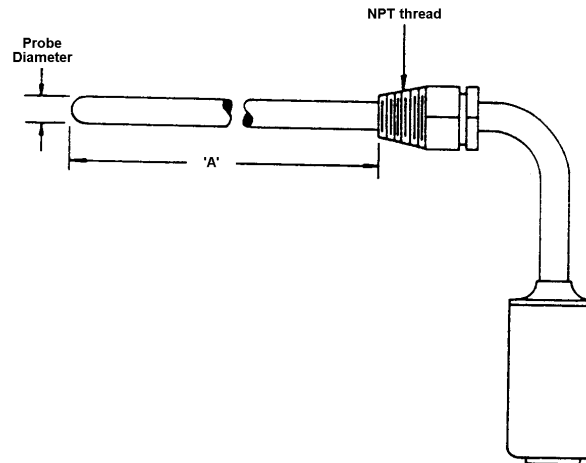

Part #: ECT-104------

Junction (Table 1)
 Calibration (Table 2)
 Diameter (Table 3)
 'A' Length (Table 4)
 inches
 Mounting Ftg.
 **

** = If the assembly is to be straight, rather than 90° bend, add "S" as the last digit in the part number.

NOTE: For any additional modifications to this assembly, add "-MOD" to the end of the part number and provide a physical description of the modification.

**Table 1
Junction**

P/N	Description
U	Ungrounded
G	Grounded
E	Exposed
UU	Uncommon-Ungrounded
GG	Dual Grounded
EE	Dual Exposed
X	Special

**Table 2
Calibration**

P/N	Description
J	Type 'J'
K	Type 'K'
E	Type 'E'
N	Type 'N'
X	Special

**Table 3
Diameter**

P/N	Description
1/8	1/8" O.D.
3/16	3/16" O.D.
1/4	1/4" O.D.
3/8	3/8" O.D.
X	Special

**Table 4
Mounting Fitting**

P/N	Description
A	1/8" NPT Adjustable
B	1/4" NPT Adjustable
C	1/2" NPT Adjustable
D	1/2" NPT Fixed †
E	3/8" NPT Adjustable
F	3/4" NPT Adjustable
X	Special

† - Only Available in 3/8" diameter

Example:

ECT-104-U-J-1/4-4.5-48-C

104 Style, Type 'J', 1/4" diameter sheath, 4.5" active length, 1/2" NPT adjustable mounting fitting



DURO-SENSE CORPORATION 869 Sandhill Ave., Carson, CA 90746

Phone: (310) 533-6877 -- Fax: (310) 533-0330 -- E-mail: sales@duro-sense.com -- Website: www.duro-sense.com

ENGINE-COMPRESSOR THERMOCOUPLES

Thermocouple Ordering Information

"106" Style

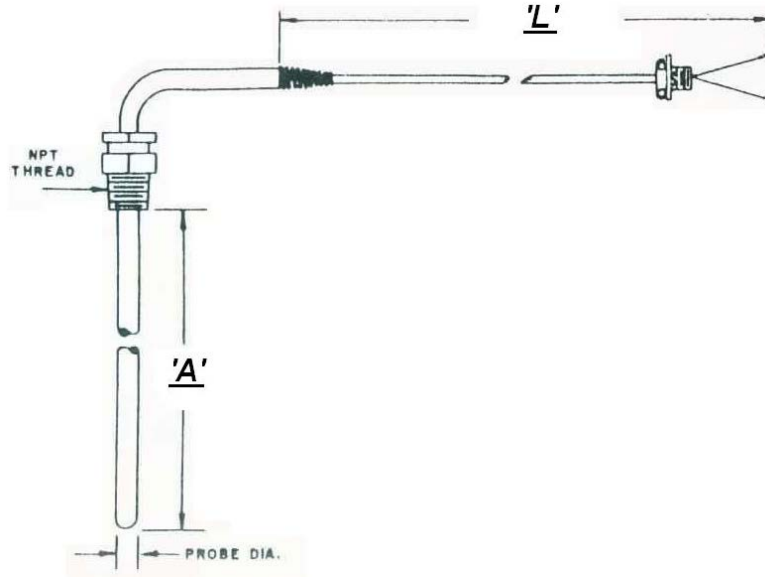

Part #: ECT-106---------

Junction (Table 1)	Calibration (Table 2)	Diameter (Table 3)	'A' Length inches	'L' Length inches	* Mounting Ftg. (Table 4)	Cable Ftg. (Table 5)	** = If SS flex armor is required, add an 'F' in this field. If it is not required, omit this field. ** = If the assembly is to be straight, rather than 90° bend, add "S" as the last digit in the part number.
-----------------------	--------------------------	-----------------------	----------------------	----------------------	------------------------------	-------------------------	---

NOTE: For any additional modifications to this assembly, add "-MOD" to the end of the part number and provide a physical description of the modification.

**Table 1
Junction**

P/N	Description
U	Ungrounded
G	Grounded
E	Exposed
UU	Uncommon-Ungrounded
GG	Dual Grounded
EE	Dual Exposed
X	Special

**Table 2
Calibration**

P/N	Description
J	Type 'J'
K	Type 'K'
E	Type 'E'
N	Type 'N'
X	Special

**Table 3
Diameter**

P/N	Description
1/8	1/8" O.D.
3/16	3/16" O.D.
1/4	1/4" O.D.
3/8	3/8" O.D.
X	Special

**Table 4
Mounting Fitting**

P/N	Description
A	1/8" NPT Adjustable
B	1/4" NPT Adjustable
C	1/2" NPT Adjustable
D	1/2" NPT Fixed †
E	3/8" NPT Adjustable
F	3/4" NPT Adjustable
X	Special

† - Only Available in 3/8" diameter

**Table 5
Cable Fitting**

P/N	Description
B	BX Connector
C	Cord Grip
X	Special

Example:

ECT-106-U-J-1/4-4.5-48-C-B

106 Style, Type 'J', 1/4" diameter sheath, 4.5" active length, 48" lead length, 1/2" NPT adjustable mounting fitting, BX connector cable fitting.



DURO-SENSE CORPORATION 869 Sandhill Ave., Carson, CA 90746

Phone: (310) 533-6877 -- Fax: (310) 533-0330 -- E-mail: sales@duro-sense.com -- Website: www.duro-sense.com



Duro-Sense Corporation

**869 Sandhill Avenue
Carson, California 90746**

Phone: **(310) 533-6877**

Fax: **(310) 533-0330**

sales@duro-sense.com